



**PROFESSIONAL AIR MOVER  
OWNER'S MANUAL**

P-800 / P-800H / P-830 / P-830H  
X-800 / X-800C / X-800H / X-800TF  
X-830 / X-830H (115V / 60Hz)

XPOWER MANUFACTURE, INC.  
220 Clary Avenue  
San Gabriel, CA 91776, USA  
Tel: 626-285-3301, Fax: 626-285-3302  
[www.xpower.ws](http://www.xpower.ws)



PLEASE READ AND SAVE THESE INSTRUCTIONS

**Index**

Introduction .....	2
Operation / Instructions.....	3
Safety Instructions.....	4
Maintenance Instructions / Troubleshooting.....	5
Specifications.....	6
Warranty / Service .....	7
Parts List .....	8
Accessories .....	9
Warranty Registration Form .....	10

## Introduction

XPOWER Air Movers are ETL/CETL Certified Professional Level Multifunctional Air Movers with the most efficient engineering design.

Features:

- Low power draw with an high velocity air flow from 3,200 to 3,600 CFM
- Super quiet motor and super lightweight.
- Easy carrying handle and stackable up to 3 units high.
- Easy and quick to disassemble for thorough cleaning and service.
- Power cord lengths are 20' for P models and 25' for X models.
- Easy cord wrap on handle.
- Luggage handle and wheels for "H" series models.
- Carpet clamp for "C" series models.
- Timer and filter for "TF" series models.
- 3-speed switch.
- Durable and rugged housing with 5 years warranty.
- 3 air-flow positions for "H" series models (0°, 20° Kickstand, 90°).
- 4 air-flow positions for other models (0°, 20°, 45°, 90°).

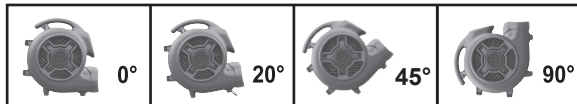

## Operation / Instructions

XPOWER Air Movers are intended to move air and to dry floors, walls, furniture, etc. Durable and easy to operate with an effective balance of static pressure and airflow, the units are suitable for a variety of applications.

1. XPOWER Air Movers are shipped ready-to-use. Prior to plugging the unit into the power source, inspect completely for any shipping damage.
2. Plug the electrical cord into the power outlet.
3. Carefully place the Air Mover unit on a stable, flat dry surface.
4. The unit is capable to be used at 4 different angles to direct air flow, except that the unit with handle is at 3 different angles.
5. Turn the switch to select desired speed, while making sure unit operates normally.
6. All Air Movers in operation must be supervised at all times.



### **AIR MOVER STORAGE:**

Air Movers can be stacked (up to 3) on their sides for storage.

### **NOTICE:**

Stacking feature is not secure for transportation. Must remove the filters before stacking. (For unit with filters)



### **Timer Instruction (For X-800TF model)**

Use the Timer to set the preferred time from 1 min to 180 min.

## **Safety Instructions**

1. To prevent electric shock, do not operate the unit in standing water. Never plug in or unplug the unit with wet hands or while standing in water.
2. To avoid risk of injury, do not direct air flow at face or any part of body.
3. To reduce the risk of fire or electric shock, do not use the Air Mover with any solid-state speed control device.
4. Use only with GFCI protected receptacles. Please contact a qualified electrician for verification and / or install GFCI receptacle if necessary.
5. Do not operate any Air Mover with a damaged cord or plug. Discard the unit or return it to an authorized service facility for examination and/or repair.
6. Unplug the Air Mover from the power supply before moving, servicing or cleaning.
7. Do not run the power cord under carpeting. Do not cover the power cord with throw rugs, runners, or similar coverings. Place the power cord away from traffic area to prevent tripping.
8. Do not allow children to play with or around an Air Mover at any time.
9. Do not move or carry an Air Mover while unit is operating.
10. All Air Movers in operation must be supervised at all times.

**Maintenance Instructions**

1. To keep the Air Mover clean, use a damp cloth to wipe the surface of the housing.
2. Never clean the Air Mover with water directly.
3. When not in use, unplug and store the Air Mover in a dry indoor place out of reach of children.
4. Always disconnect the Air Mover from its power source before performing any maintenance or cleaning.
5. Clean the filters ( for unit with filters) often as necessary to avoid loss of airflow when available.

**Troubleshooting**

For any problems not listed below, call your local distributor or contact our Service Department.

PROBLEM	POSSIBLE CAUSE	SOLUTION
Air Mover not running	No power input	Plug in the Air Mover; check circuit breaker
	Switch not turned on	Turn on switch
	Air Mover fan wheel jammed	Remove material jamming fan wheel
	Intake or exhaust blocked	Turn unit off and allow to cool, then remove blockage
Air Mover vibrates	Accumulation of dirt on fan blades	Clean Air Mover fan blades

## Specifications

Model	P-800/X-800	P-800H/X-800H	X-800C	X-800TF	P-830/X-830	P-830H/X-830H
<b>Volt/Frequency</b>	115V,60Hz	115V,60Hz	115V,60Hz	115V,60Hz	115V,60Hz	115V,60Hz
<b>Power</b>	3/4 HP	3/4 HP	3/4 HP	3/4 HP	1 HP	1 HP
<b>Amp</b>	7.5 Amps	7.5 Amps	7.5 Amps	7.5 Amps	8.5 Amps	8.5 Amps
<b>Unit Weight</b>	23Lbs./24.5Lbs.	26Lbs./27.5Lbs.	24.7Lbs.	24.7Lbs.	24Lbs./25.5Lbs.	27Lbs./28.5Lbs.
<b>Speeds</b>	Three	Three	Three	Three	Three	Three
<b>Size(WxDxH)</b>	15.9x17.5x18.5 in.	15.9x18.7x18.7 in.	15.9x17.5x18.5 in.	15.9x17.5x18.5 in.	15.9x17.5x18.5 in.	15.9x18.7x18.7 in.
<b>Handle/Wheels</b>	Optional	Incl.	Optional	Optional	Optional	Incl.
<b>Carpet clamp</b>	Optional	Optional	Incl.	Optional	Optional	Optional
<b>Timer</b>	N.A.	N.A.	N.A.	Incl.	N.A.	N.A.
<b>Filter</b>	Optional	Optional	Optional	Incl.	Optional	Optional
<b>Cord Length</b>	20 Ft. / 25 Ft.	20 Ft. / 25 Ft.	25 Ft.	25 Ft.	20 Ft. / 25 Ft.	20 Ft. / 25 Ft.
<b>Overheating Protecting</b>	Thermally Protected	Thermally Protected	Thermally Protected	Thermally Protected	Thermally Protected	Thermally Protected
<b>Rated Airflow (on high)</b>	3200 CFM	3200 CFM	3200 CFM	3200 CFM	3600 CFM	3600 CFM
<b>Positions</b>	4(0°, 20°, 45°, 90°)	3 (0°, 20°, 90°)	4(0°, 20°, 45°, 90°)	4(0°, 20°, 45°, 90°)	4(0°, 20°, 45°, 90°)	3 (0°, 20°, 90°)
<b>Housing</b>	PP / ABS	PP / ABS	ABS	ABS	PP / ABS	PP / ABS

\* All models are ETL/CETL certified

## XPOWER LIMITED WARRANTY

XPOWER Warranty covers the unit from defects in materials and craftsmanship. The Warranty covers normal use for a term of one year from the original date of purchase including parts, labor and one way shipping. The XPOWER Air Mover Housing and handle are covered for a term of five years from the date of original purchase.

### **Important !**

This Warranty does not cover signs of misuse including, but not limited to, a unit that has been dropped, subjected to water damage, tampered with, improper voltage use and unauthorized maintenance and repairs. The POWER CORD and filters are not covered by the warranty.

### Service

In order to receive service or replacement parts under warranty, you must:

- A. Call for a Return Merchandise Authorization (RMA) number through our Service Department and obtain ship back instructions.
- B. Have original proof of purchase.
- C. Use original non damaged packaging or Industrial certified packaging method.

The end user will be responsible to ship the unit (with the RMA number showing on the shipping label) to the XPOWER Service Department. Upon inspection, we will advise you of the repairs needed and the cost (if applicable). XPOWER will provide repair or replacement parts depending on warranty.



**800 Series Parts List**

Item No.	Parts Name	Item No.	Parts Name
800-1	Left Housing	800-2	Grid Cover (Motor Side)
800-3	Timer & Switch Plate	800-4-1/2	Switch Knob & Timer Knob
800-5	Switch	800-6	Motor
800-7	Right Housing	800-8	Power Cord
800-9	Fan	800-10	Grid Cover (Fan Side)
800-11	Air Outlet Grid Cover	800-12	Kick Stand
800-13	Rubber Feet (Not Shown)	800-14	Screws and Nuts (Not Shown)
800-15	Capacitor	800-16	Filters

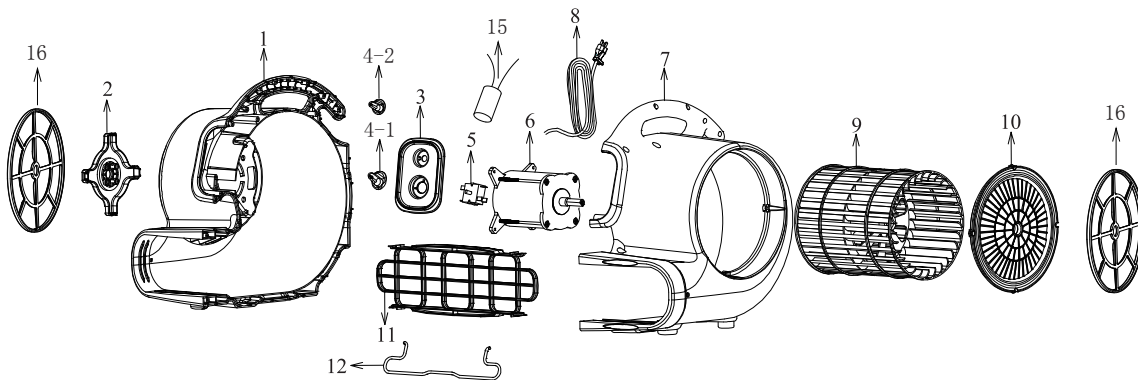

## Accessories

### **Luggage Handle & Wheels (for 800H and 830H models)**

XPOWER Air Mover Model P-800H, P-830H, X-800H and X-830H comes with built-in extendable luggage handle and wheels for easy transportation and mobility.



### **Carpet clamp (for 800C models)**

XPOWER Air Mover Model X-800C, comes with a carpet clamp specifically for drying under the carpets.



### **Filters (Optional)**

A set of Filters is available for the Air Mover models which will help prevent small debris and dust from entering the unit. To clean the filters: Remove the filters from the unit and wash with warm soapy water, rinse with clean water and let dry thoroughly before reinstalling.

**Installation:**  
Filters snaps into the air inlets.

**Note:**  
The filter I is for Motor Side,  
The filter II is for Fan Side



**Filter Removal:**  
Pull the filters off the unit.

**Note:**  
After cleaning make sure the  
filters are dry before  
reinstalling.



## WARRANTY REGISTRATION

Please complete and mail or fax for your product warranty. For a multiple units, please list serial numbers on a separate sheet of paper. Address: XPOWER MANUFACTURE, INC, 220 Clary Avenue San Gabriel, CA 91776, USA  
Tel: (626) 285-3301; Fax: (626) 285-3302

Company Name / Contact Person / Title \_\_\_\_\_

Address \_\_\_\_\_ City \_\_\_\_\_

State / Province \_\_\_\_\_ Zip \_\_\_\_\_ Country \_\_\_\_\_

Phone \_\_\_\_\_ Fax \_\_\_\_\_ E-mail \_\_\_\_\_

**Model #** \_\_\_\_\_ **Serial #:** \_\_\_\_\_

**Date of Purchase** \_\_\_\_ / \_\_\_\_ / \_\_\_\_ **Purchased From** \_\_\_\_\_

**Additional Comments / Suggestions** \_\_\_\_\_



[New & Reconditioned Equipment & Parts - www.southeasternequipment.net](http://www.southeasternequipment.net)

From: \_\_\_\_\_  
\_\_\_\_\_  
\_\_\_\_\_



TO:

XPOWER MANUFACTURE, INC.

220 Clary Avenue

San Gabriel, CA 91776, USA

Tel: 626-285-3301, Fax: 626-285-3302





## PROFESSIONAL AIR MOVER OWNER'S MANUAL

P-800 / P-800H / P-830 / P-830H  
X-800 / X-800C / X-800H / X-800TF  
X-830 / X-830H (115V / 60Hz)

XPOWER MANUFACTURE, INC.  
220 Clary Avenue  
San Gabriel, CA 91776, USA  
Tel: 626-285-3301, Fax: 626-285-3302  
[www.xpower.ws](http://www.xpower.ws)



PLEASE READ AND SAVE THESE INSTRUCTIONS

### Introduction

XPOWER Air Movers are ETL/CETL Certified Professional Level Multifunctional Air Movers with the most efficient engineering design.

#### Features:

- Low power draw with an high velocity air flow from 3,200 to 3,600 CFM
- Super quiet motor and super lightweight.
- Easy carrying handle and stackable up to 3 units high.
- Easy and quick to disassemble for thorough cleaning and service.
- Power cord lengths are 20' for P models and 25' for X models.
- Easy cord wrap on handle.
- Luggage handle and wheels for "H" series models.
- Carpet clamp for "C" series models.
- Timer and filter for "TF" series models.
- 3-speed switch.
- Durable and rugged housing with 5 years warranty.
- 3 air-flow positions for "H" series models (0°, 20° Kickstand, 90°).
- 4 air-flow positions for other models (0°, 20°, 45°, 90°).

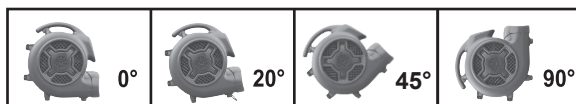

## Index

Introduction .....	2
Operation / Instructions.....	3
Safety Instructions.....	4
Maintenance Instructions / Troubleshooting.....	5
Specifications.....	6
Warranty / Service .....	7
Parts List .....	8
Accessories .....	9
Warranty Registration Form .....	10

- 1 -

## Operation / Instructions

XPOWER Air Movers are intended to move air and to dry floors, walls, furniture, etc. Durable and easy to operate with an effective balance of static pressure and airflow, the units are suitable for a variety of applications.

1. XPOWER Air Movers are shipped ready-to-use. Prior to plugging the unit into the power source, inspect completely for any shipping damage.
2. Plug the electrical cord into the power outlet.
3. Carefully place the Air Mover unit on a stable, flat dry surface.
4. The unit is capable to be used at 4 different angles to direct air flow, except that the unit with handle is at 3 different angles.
5. Turn the switch to select desired speed, while making sure unit operates normally.
6. All Air Movers in operation must be supervised at all times.



### **AIR MOVER STORAGE:**

Air Movers can be stacked (up to 3) on their sides for storage.

### **NOTICE:**

Stacking feature is not secure for transportation. Must remove the filters before stacking.  
(For unit with filters)



### **Timer Instruction (For X-800TF model)**

Use the Timer to set the preferred time from 1 min to 180 min.

- 3 -

## Safety Instructions

1. To prevent electric shock, do not operate the unit in standing water. Never plug in or unplug the unit with wet hands or while standing in water.
2. To avoid risk of injury, do not direct air flow at face or any part of body.
3. To reduce the risk of fire or electric shock, do not use the Air Mover with any solid-state speed control device.
4. Use only with GFCI protected receptacles. Please contact a qualified electrician for verification and / or install GFCI receptacle if necessary.
5. Do not operate any Air Mover with a damaged cord or plug. Discard the unit or return it to an authorized service facility for examination and/or repair.
6. Unplug the Air Mover from the power supply before moving, servicing or cleaning.
7. Do not run the power cord under carpeting. Do not cover the power cord with throw rugs, runners, or similar coverings. Place the power cord away from traffic area to prevent tripping.
8. Do not allow children to play with or around an Air Mover at any time.
9. Do not move or carry an Air Mover while unit is operating.
10. All Air Movers in operation must be supervised at all times.

- 4 -

## Specifications

Model	P-800/X-800	P-800H/X-800H	X-800C	X-800TF	P-830/X-830	P-830H/X-830H
<b>Volt/Frequency</b>	115V,60Hz	115V,60Hz	115V,60Hz	115V,60Hz	115V,60Hz	115V,60Hz
<b>Power</b>	3/4 HP	3/4 HP	3/4 HP	3/4 HP	1 HP	1 HP
<b>Amp</b>	7.5 Amps	7.5 Amps	7.5 Amps	7.5 Amps	8.5 Amps	8.5 Amps
<b>Unit Weight</b>	23Lbs./24.5Lbs.	26Lbs./27.5Lbs.	24.7Lbs.	24.7Lbs.	24Lbs./25.5Lbs.	27Lbs./28.5Lbs.
<b>Speeds</b>	Three	Three	Three	Three	Three	Three
<b>Size(WxDxH)</b>	15.9x17.5x18.5 in.	15.9x18.7x18.7 in.	15.9x17.5x18.5 in.	15.9x17.5x18.5 in.	15.9x17.5x18.5 in.	15.9x18.7x18.7 in.
<b>Handle/Wheels</b>	Optional	Incl.	Optional	Optional	Optional	Incl.
<b>Carpet clamp</b>	Optional	Optional	Incl.	Optional	Optional	Optional
<b>Timer</b>	N.A.	N.A.	N.A.	Incl.	N.A.	N.A.
<b>Filter</b>	Optional	Optional	Optional	Incl.	Optional	Optional
<b>Cord Length</b>	20 Ft. / 25 Ft.	20 Ft. / 25 Ft.	25 Ft.	25 Ft.	20 Ft. / 25 Ft.	20 Ft. / 25 Ft.
<b>Overheating Protecting</b>	Thermally Protected	Thermally Protected	Thermally Protected	Thermally Protected	Thermally Protected	Thermally Protected
<b>Rated Airflow (on high)</b>	3200 CFM	3200 CFM	3200 CFM	3200 CFM	3600 CFM	3600 CFM
<b>Positions</b>	4(0°, 20°, 45°, 90°)	3 (0°, 20°, 90°)	4(0°, 20°, 45°, 90°)	4(0°, 20°, 45°, 90°)	4(0°, 20°, 45°, 90°)	3 (0°, 20°, 90°)
<b>Housing</b>	PP / ABS	PP / ABS	ABS	ABS	PP / ABS	PP / ABS

\* All models are ETL/CETL certified

- 6 -

## Maintenance Instructions

1. To keep the Air Mover clean, use a damp cloth to wipe the surface of the housing.
2. Never clean the Air Mover with water directly.
3. When not in use, unplug and store the Air Mover in a dry indoor place out of reach of children.
4. Always disconnect the Air Mover from its power source before performing any maintenance or cleaning.
5. Clean the filters ( for unit with filters) often as necessary to avoid loss of airflow when available.

## Troubleshooting

For any problems not listed below, call your local distributor or contact our Service Department.

PROBLEM	POSSIBLE CAUSE	SOLUTION
Air Mover not running	No power input	Plug in the Air Mover; check circuit breaker
	Switch not turned on	Turn on switch
	Air Mover fan wheel jammed	Remove material jamming fan wheel
	Intake or exhaust blocked	Turn unit off and allow to cool, then remove blockage
Air Mover vibrates	Accumulation of dirt on fan blades	Clean Air Mover fan blades

- 5 -

## XPOWER LIMITED WARRANTY

XPOWER Warranty covers the unit from defects in materials and craftsmanship. The Warranty covers normal use for a term of one year from the original date of purchase including parts, labor and one way shipping. The XPOWER Air Mover Housing and handle are covered for a term of five years from the date of original purchase.

### **Important !**

This Warranty does not cover signs of misuse including, but not limited to, a unit that has been dropped, subjected to water damage, tampered with, improper voltage use and unauthorized maintenance and repairs. The POWER CORD and filters are not covered by the warranty.

## Service

In order to receive service or replacement parts under warranty, you must:

- A. Call for a Return Merchandise Authorization (RMA) number through our Service Department and obtain ship back instructions.
- B. Have original proof of purchase.
- C. Use original non damaged packaging or Industrial certified packaging method.

The end user will be responsible to ship the unit (with the RMA number showing on the shipping label) to the XPOWER Service Department. Upon inspection, we will advise you of the repairs needed and the cost (if applicable). XPOWER will provide repair or replacement parts depending on warranty.

- 7 -



### 800 Series Parts List

Item No.	Parts Name	Item No.	Parts Name
800-1	Left Housing	800-2	Grid Cover (Motor Side)
800-3	Timer & Switch Plate	800-4-1/2	Switch Knob & Timer Knob
800-5	Switch	800-6	Motor
800-7	Right Housing	800-8	Power Cord
800-9	Fan	800-10	Grid Cover (Fan Side)
800-11	Air Outlet Grid Cover	800-12	Kick Stand
800-13	Rubber Feet (Not Shown)	800-14	Screws and Nuts (Not Shown)
800-15	Capacitor	800-16	Filters

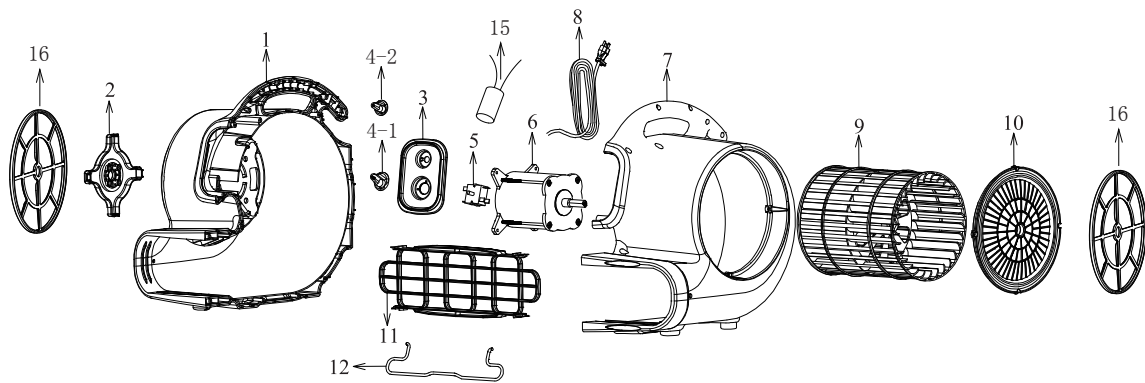

- 8 -

## WARRANTY REGISTRATION

Please complete and mail or fax for your product warranty. For a multiple units, please list serial numbers on a separate sheet of paper. Address: XPOWER MANUFACTURE, INC, 220 Clary Avenue San Gabriel, CA 91776, USA  
Tel: (626) 285-3301; Fax: (626) 285-3302

Company Name / Contact Person / Title \_\_\_\_\_

Address \_\_\_\_\_ City \_\_\_\_\_

State / Province \_\_\_\_\_ Zip \_\_\_\_\_ Country \_\_\_\_\_

Phone \_\_\_\_\_ Fax \_\_\_\_\_ E-mail \_\_\_\_\_

Model # \_\_\_\_\_ Serial #: \_\_\_\_\_

Date of Purchase \_\_\_\_/\_\_\_\_/\_\_\_\_ Purchased From \_\_\_\_\_

Additional Comments / Suggestions \_\_\_\_\_



### Accessories

#### **Luggage Handle & Wheels (for 800H and 830H models)**

XPOWER Air Mover Model P-800H, P-830H, X-800H and X-830H comes with built-in extendable luggage handle and wheels for easy transportation and mobility.

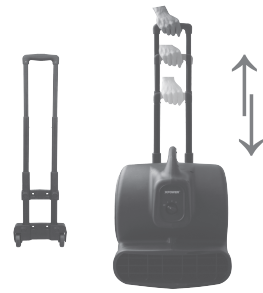

#### **Carpet clamp (for 800C models)**

XPOWER Air Mover Model X-800C, comes with a carpet clamp specifically for drying under the carpets.



#### **Filters (Optional)**

A set of Filters is available for the Air Mover models which will help prevent small debris and dust from entering the unit. To clean the filters: Remove the filters from the unit and wash with warm soapy water, rinse with clean water and let dry thoroughly before reinstalling.

Installation:  
Filters snaps into the air inlets.

Note:  
The filter I is for Motor Side,  
The filter II is for Fan Side



Filter Removal:  
Pull the filters off the unit.

Note:  
After cleaning make sure the  
filters are dry before  
reinstalling.



From: \_\_\_\_\_  
\_\_\_\_\_  
\_\_\_\_\_

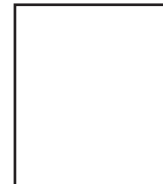

TO:  
XPOWER MANUFACTURE, INC.  
220 Clary Avenue  
San Gabriel, CA 91776, USA  
Tel: 626-285-3301, Fax: 626-285-3302

