

7765

Rider Sweeper-Scrubber



Smart cleaning.

A Nilfisk-Advance Brand

 **Advance**
Industrial Cleaning Equipment

 **Southeastern**
EQUIPMENT & SUPPLY, INC.

800.440.6723
www.southeasternequipment.net

Operator's Compartment – deeply padded seat and power steering in operator's compartment provide top-of-the-line comfort

Solution/Recovery Tanks – 100 gallon stainless steel solution/recovery tanks with tilt-out cleaning

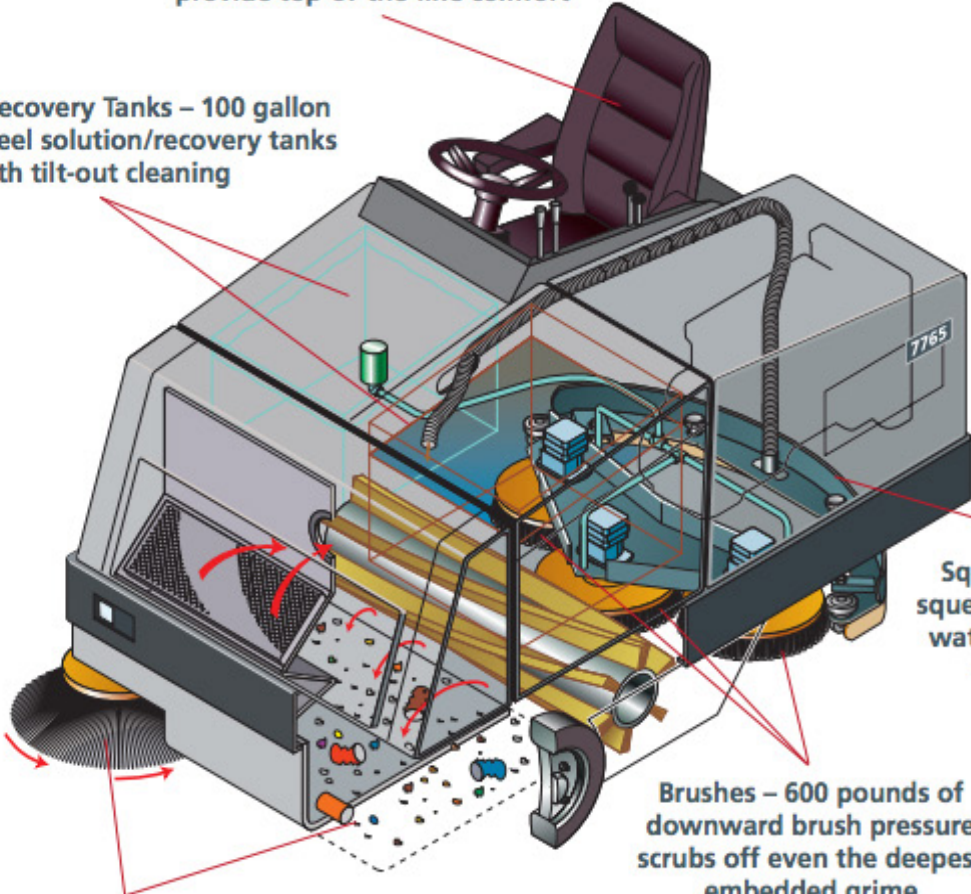

Squeegee – Accu-Track™ squeegee provides superior water pickup even during the tightest turns

Brushes – 600 pounds of downward brush pressure scrubs off even the deepest embedded grime

Sweeping System – separate sweeping system with variable or manual dump hopper picks up dirt and debris before scrubbing



Patented Accu-Track™ squeegee provides superior water pick-up even during the tightest turns.



Maintenance is a breeze with easy-to-reach engine, electrical and hydraulic components.



Recovery tank tilts out for quick and easy clean-up, reducing the amount of time needed for draining and refilling.

800.440.6723 • www.southeasternequipment.net

7765 Rider Sweeper-Scrubber

Clean Your Toughest Jobs With This Powerful Rider!

The 7765 powerfully scrubs dirt, grease and grime, as well as removes any loose debris. It will remove virtually all of the cleaning solution that it puts down, leaving your facility with a clean, dry floor surface. Big on performance and capacity, this true sweeper/scrubber is the answer to your toughest cleaning jobs.

Powerful, aggressive cleaning features include:

- All hydraulic operation
- Up to 600 pounds of downward scrub brush pressure
- Patented Accu-Track™ swing squeegee with break-away feature
- 86 hp GM gas or LP / 47.3 hp Mitsubishi diesel meet stringent EPA emission regulations

Extra large capacity features include:

- 100 gallon stainless steel solution and recovery tanks
- All-steel, 16 cubic foot debris hopper
- Broad 54 inch scrubbing and 60 inch sweeping paths
- Heavy-duty, 107 square foot dust filter with automatic shaker system



Scrub brushes with 600 pounds of downward pressure provide the most aggressive cleaning possible, yet brushes can be easily changed without tools.

FEATURES AND BENEFITS

Productivity – Two machines in one – sweeper and scrubber. Picks up debris and scrubs aggressively. Patented Accu-Track™ swing squeegee with break-away feature. Dries the floor even on tight turns. Provides more productivity and less downtime because of low maintenance. All hydraulic systems and power steering. Large tilt-out, easy-to-clean recovery tank for longer floor time between clean-ups. Large debris hopper and dust collection system. Manual or variable 60 inch dump system.

Durability – Heavy gauge welded steel chassis with wraparound bumper. All-steel construction. Accu-Track™ break-away squeegee.

Design – Heavy-duty, all-steel construction. Ergonomic operator's compartment reduces operator's fatigue.

Safety – Rack and pinion power steering for better handling. Hopper safety arm.

Excellent front or rear view from operator's compartment.

Complete operator's manual and training video.

Ideal applications include:

- Manufacturing Plants
- Discount Warehouses
- Food Warehouses
- Parking Garages
- Automotive Plants



800.440.6723 • www.southeasternequipment.net

 **Advance**
Industrial Cleaning Equipment

Technical Specifications

	7765 with Variable Dump	7765 with Manual Dump
Model	7765 with Variable Dump	7765 with Manual Dump
Scrubbing Path	54 in (137 cm)	54 in (137 cm)
Scrub Brush Pressure	600 lb (272 kg)	600 lb (272 kg)
Sweeping Path	60 in (152 cm)	50 in (127 cm)
Solution/Recovery Tanks	100 gal (380.1 L) each	100 gal (380.1 L) each
Hopper Capacity	16 ft ³ (454 L)	6 ft ³ (170 L)
Vacuum Fan	Hydraulically driven, high volume	Hydraulically driven, high volume
U-Turn Aisle Width	120 in (305 cm)	120 in (305 cm)
Turning Radius (left or right)	82 in (208 cm)	82 in (208 cm)
Dust Filter	107 ft ² (10 m ²)	N/A
Main Broom	50 in (106.7 cm)	50 in (106.7 cm)
Side Broom	24 in (61 cm)	Optional
Brushes (3)	18 in (45 cm)	18 in (45 cm)
Engines	86 hp GM 3.0 L MPFI gas or LP / 47.3 hp Mitsubishi diesel	86 hp GM 3.0 L MPFI gas or LP / 47.3 hp Mitsubishi diesel
Dimensions	107 x 59 x 61.5 in (271 x 150 x 156 cm)	107 x 59 x 61.5 in (271 x 150 x 156 cm)
Height with Overhead Guard	85.5 in (217 cm)	85.5 in (217 cm)
Weight	4,350 lb (1,973 kg)	3,900 lb (1,769 kg)

Specifications are subject to change without notice.

Standard features:

- All hydraulic systems and power steering
- Large, easy-to-clean recovery tank for longer floor time between clean-ups
- Large debris hopper and dust collection system
- Manual or variable 60 inch dump system
- Heavy gauge welded steel chassis with wraparound bumper
- All-steel construction
- Accu-Track™ break-away squeegee
- Rack and pinion power steering for better handling
- Hopper safety arm
- Excellent front or rear view from operator's compartment

14600 21st Avenue North
Plymouth, MN 55447-3408
www.advance-us.com
Phone 800-214-7700
Fax 800-989-6566

240 Superior Boulevard
Mississauga, Ontario, Canada L5T 2L2
www.nilfisk-advance.com
Phone 800-668-8400
Fax 800-263-5111



Ask about our leasing options.

©2010 Nilfisk-Advance, Inc. Form L3101A 1-21-10

 **Advance**
Industrial Cleaning Equipment

A Nilfisk-Advance Brand

www.advance-us.com/industrial

Southeastern
EQUIPMENT & SUPPLY, INC.

800.440.6723

www.southeasternequipment.net