

OWNER'S MANUAL

THE PROSCRUB Automatic 20" Floor Autoscrubber



EQUIPMENT DISTRIBUTOR: _____
DIST. SALESPERSON: _____ PHONE #: _____
DATE OF PURCHASE: _____ INVOICE #: _____



WWW.AZTECPRODUCTS.COM

800-331-1423 * 201 COMMERCE DRIVE, MONTGOMERYVILLE, PA 18936

07-2019

TABLE OF CONTENTS

INTRODUCTION & GENERAL SAFETY MESSAGE INFORMATION	PG 3-5
PROSCRUB SPECIFICATIONS	PG 5
BEFORE OPERATION CHECKLIST	PG 6
DRAINING AND FILLING THE TANKS	PG 7-8
PROSCRUB DIAGRAM	PG 8
PROSCRUB OPERATION	PG 9-10
PROSCRUB HELPFUL HINTS	PG 10
HOW TO REMOVE SQUEEGEE (without tools)	PG 10
STORAGE AND HANDLING SAFETY INFORMATION	PG 11
PROSCRUB MAINTENANCE SCHEDULE	PG 12-13
BATTERY MAINTENANCE SCHEDULE & BATTERY CHARGING	PG 14-15
<i>REPLACEMENT PARTS AND DIAGRAMS:</i>	
SOLUTION TANK PARTS	PG 16
VACUUM TANK PARTS	PG 17
SHROUD ASSEMBLY PARTS	PG 18
SQUEEGEE ASSEMBLY PARTS	PG 19
DRIVE ASSEMBLY PARTS	PG 20
CONTROL PANEL PARTS	PG 21
WIRING DIAGRAM	PG 22
TROUBLESHOOTING	PG 23
RETURN GOODS POLICY	PG 24
RETAILER / DISTRIBUTOR CONTACT INFO	PG 24
PROSCRUB WARRANTY	PG 25

INTRODUCTION

Thank you for purchasing this Aztec Products, Inc. machine. You have purchased a quality product and we welcome you to the Aztec family. It is critically important to utilize proper training, understanding, maintenance and care for this product. Neglect of the Safety Messages, especially the **DANGER**, **WARNING**, **CAUTION** and **NOTICE** statements throughout this Owner's Manual may lead to serious injury or death, and/or cause damage to the floor and/or facility.

For best results from your Aztec machine, you must read and understand this Owner's Manual, and follow all operation guidelines and safety messages. Protect your **WARRANTY** by following all maintenance guidelines and keeping a dated log. If a problem should arise, consult an authorized Aztec service center.

All information in this Owner's Manual is up to date and based on the latest product information available at the time of printing. Aztec Products, Inc. reserves the right to make changes at any time without notice or incurring obligation. This Owner's Manual and the maintenance log must be kept as a permanent part of the machine and remain with the machine if resold.

No part of this document may be copied or reproduced without written permission.

GENERAL SAFETY MESSAGE INFORMATION

Your safety and the safety of others is very important. As the manufacturer, we have provided important safety messages throughout this manual and on the machine. The purpose of these safety messages is to prevent damage to you, your machine, the property, and/or the environment.

Please read and understand this information thoroughly. A safety message alerts you to potential hazards that could result in injury or death, and/or cause damage to the floor and/or facility. Each safety message is preceded by a universal safety alert symbol (!) and one of these safety words: **DANGER**, **WARNING**, **CAUTION**, or **NOTICE**. These signal words mean:

	DANGER indicates a hazardous situation which, if not avoided, will result in death or serious injury
	WARNING indicates a hazardous situation which, if not avoided, could result in death or serious injury.
	CAUTION indicates a hazardous situation which, if not avoided, could result in minor or moderate injury
	NOTICE is used to address practices not related to physical injury

IMPORTANT SAFETY INFORMATION

The 20" ProScrub automatic scrubber is designed to scrub floors in an indoor environment and is not recommended for any other use. Call Aztec 800-331-1423 for additional application questions.



Never use flammable or explosive cleaning solutions such as gasoline, kerosene, solvents, thinners, etc. in the solution tank in an attempt to remove grease, oil, tar, etc. from floors. Never operate scrubber where flammable liquids or gases are present.



Keep hands and feet clear of moving parts to avoid injury.



Extreme caution should be used whenever a ramp is used to load or unload this autoscrubber. Do not attempt to make turns on the ramp. Personal injury or damage to machine or property may occur.



Do not attempt to ride on or otherwise attach any type of rider platform to this scrubber. Injury and property damage may occur.

0



Safety is a full-time, every day job. Never let an untrained or irresponsible person operate the machine. They may hurt themselves and/or damage the floor or other property.



Do not leave this machine unattended while the machine is ON. Damage to floor surface or other property may occur.



Never operate this autoscrubber with the dash panel removed. Always operate this autoscrubber with the brush cover, battery cover, and all side panels secured and in the correct position. Personal injury or damage to machine or property may occur.



Remove all loose objects from floor before operating. Loose objects may become dangerous projectiles when they come into contact with revolving brushes/pads.



Keep autoscrubber moving along floor to avoid burning or damage to floor surface.

IMPORTANT SAFETY INFORMATION *continued*

NOTICE

Make sure the operator receives adequate instruction before operating the equipment.

NOTICE

Do not allow children to operate the machine. Keep children and pets away from the area of operation.

PROSCRUB SPECIFICATIONS

ProScrub Dimensions	Length: 44" (111.76 cm) Width: 23" (58.42 cm) Height: 35" (88.9 cm)
Solution Tank Capacity	12 Gallons (45.4 Liters)
Recovery Tank Capacity	15 Gallons (56.8 Liters)
Cleaning Path	20" (51 cm)
Pad/brush Diameter	20" (51 cm)
Squeegee Width	30" (76 cm)
Brush Motor	$\frac{3}{4}$ hp, 220 RPM
Vacuum Motor	$\frac{1}{2}$ hp, 2 stage, 24volt
Scrubbing Pressure	65#
Batteries	Two (2) 130 amp/hour, 12volt Deep cycle, lead/acid

PROTECT YOUR WARRANTY!

Read this Owner's Manual carefully and keep it with machine at all times; all questions regarding the care and safety of this equipment:

AZTEC PRODUCTS

800-331-1423 / 215-393-4700

info@aztecproducts.com

www.aztecproducts.com

BEFORE OPERATION CHECKLIST

Before beginning your pre-operation checklist, the machine must be on a level surface, with the machine switch in the OFF position. Always check the following items before you start the machine:

A. READ AND UNDERSTAND ALL SAFETY MESSAGES

Carefully read and understand all **SAFETY INSTRUCTIONS** on pgs 3-6.

B. CHECK THE GENERAL CONDITION OF THE MACHINE

- 1.) Look around and underneath the machine for signs of leaks.
- 2.) Look for signs of damage.
- 3.) Check that all covers are in place, and all nuts, bolts and screws are tightened.
- 4.) Address all of the above issues before proceeding.

C. CHECK THE MAINTENANCE SCHEDULE

Review the **MAINTENANCE SCHEDULE** on pgs 12-13. Perform any maintenance necessary before proceeding.

D. INSTALL FRESH PADS OR BRUSHES

CAUTION

Before tipping back machine, empty the tanks of all fluids. Liquid can spill out as you tip back machine and may cause damage to floor.

CAUTION

Do not leave machine unattended while tilted back; machine is not stable in tipped back position and must be held in tilted back position by an attendant.

NOTICE

Please responsibly dispose of used pads and brushes.

BRUSH INSTALLATION (see pg 8 for diagram)

- 1.) Get an assistant – this is a 2-person job
- 2.) Lower the brush head by stepping down on the pedal; push pedal forward to lower
- 3.) Position squeegee so that it is centered behind the autoscrubber
- 4.) Tilt autoscrubber back onto squeegee to access motor hub for installation; do not leave the autoscrubber tilted back any longer than necessary to avoid damaging squeegee blades

PAD INSTALLATION (see pg 8 for diagram)

- 1.) Get an assistant – this is a 2-person job
- 2.) Remove plastic centerlok from pad driver
- 3.) Center pad on a pad driver and re-attach centerlok
- 4.) Be sure to attach pad to pad driver before installing driver to motor hub

DRAINING AND FILLING THE TANKS

⚠ WARNING

Use only nonflammable chemicals. Damage or personal injury may occur.

⚠ CAUTION

Use only non-foaming detergents and dilute according to the manufacturer's instructions. If using powdered cleaners, dissolve thoroughly before adding to solution tank.

⚠ CAUTION

The Recovery Tank must be drained every time before refilling the solution tank. If it is not drained before solution tank is refilled, foam or water will enter the vacuum standpipe and damage will occur. This damage is not covered by warranty.

⚠ CAUTION

Do not fill with boiling water. Temperature must not exceed 140 F. Damage will occur to the tanks. This damage is not covered by warranty.

NOTICE

Rinse and flush solution tank thoroughly with clean water after each use. This will prevent chemical buildup. This will prevent odors or mildew from forming.

NOTICE

Before filling or draining either tank, make sure all switches are at the "OFF" position.

NOTICE

When moving the scrubber to either fill or drain, make sure brushes and squeegee are in the "UP" position.

DRAINING THE PROSCRUB RECOVERY TANK:

- 1.) Make sure *Solution Control Knob* is completely turned to OFF position
- 2.) Remove black recovery tank lid
- 3.) Remove Black Drain Hose from holder; place hose end over a drain and unscrew cap to start flow
- 4.) When recovery tank is almost empty, lift lid like you would to examine batteries and hold lid diagonally to fully drain
- 5.) Close tank
- 6.) Unscrew lid on recovery tank and use hose to rinse out tank
- 7.) Screw cap back on *Black Drain Hose* and replace drain hose securely

DRAINING AND FILLING THE TANKS *continued*

DRAINING THE PROSCRUB SOLUTION TANK:

- 1.) Make sure *Solution Control Knob* is completely turned to OFF position
- 2.) Pull clear hose off bracket at back of the machine and drain into a bucket or into floor drain
- 3.) Turn *Solution Control Knob* clockwise to clean out solution flow system
- 4.) Rinse solution tank with clean water through *Black Drain Hose*
- 5.) Reconnect *Black Drain Hose* to bracket securely; make sure it is tightly connected

FILLING THE PROSCRUB SOLUTION TANK:

- 1.) Make sure *Solution Control Knob* is completely turned to OFF position
- 2.) Fill the tank with up to 14 gallons of water and chemical solution
- 3.) The *Clear Fill Indicator Hose* can be used as a fluid fill indicator level if it is unplugged and held at the same height as if plugged in
- 4.) If the Clear Fill Indicator Hose has been used as a fluid fill indicator, plug it back in when tank is being filled

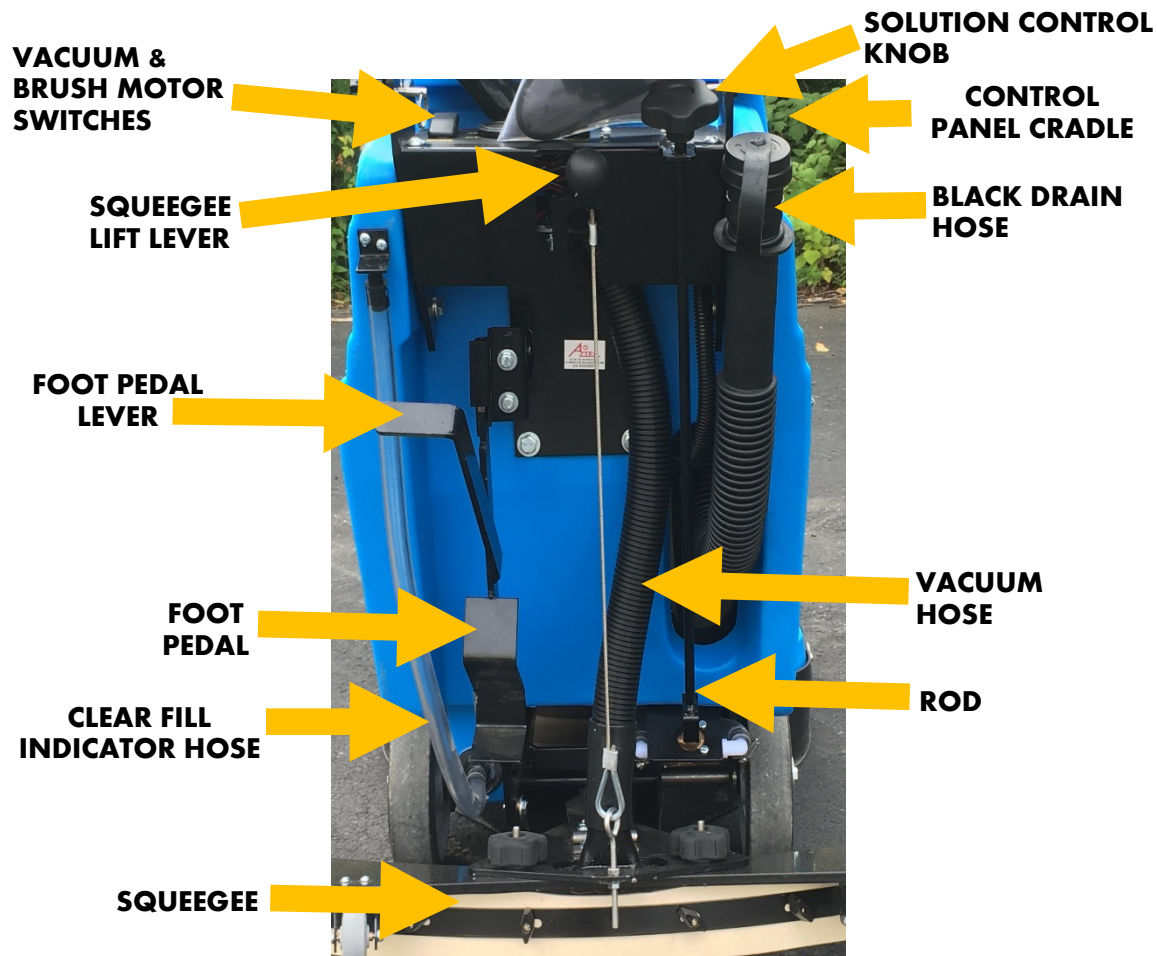

PROSCRUB OPERATION

For your safety, to ensure compliance with environmental regulations, and to maximize the service life of your equipment, it is very important to take a few minutes before you operate this machine to check its condition. Be sure to take care of any problem you find, or have your service dealer correct it before you operate this machine.

WARNING

Improperly maintaining this machine, or failure to correct a problem before operation, may cause a malfunction in which you can be seriously hurt or killed. Always perform a pre-operation inspection before each use, and correct any problem.

WARNING

Avoid use in areas with floor obstruction such as thresholds and floor outlet boxes. Avoid use in areas with loose debris or small objects that may become caught in the rotating pad.

CAUTION

READ and UNDERSTAND all instructions and safety messages before operating this machine. Follow the instructions given in this Owner's Manual and the training given by your supervisor for the safe operation of this machine. Failure to do so can result in personal injury and/or damage to the machine or property.

NOTICE

The ProScrub autoscrubber should only be operated by fully qualified maintenance personnel. Do not operate, maintain, or service this autoscrubber unless you are trained and authorized.

NOTICE

This machine is not suitable for use around hazardous dust or other hazardous materials.

NOTICE

Do not use this machine on surfaces with a gradient exceeding 2%.

Refer to the **GENERAL OPERATION SAFETY** Information on pgs 3-5 and the **BEFORE OPERATION CHECKLIST** on pg 6 before operating the ProScrub:

1. Lower squeegee by releasing the *Squeegee Lift Lever* and lowering it from the "locked" position.
2. Push top of *Foot Pedal Lever* forward to release the pad drive/brush drive down.
3. Turn *Vacuum Motor Switch* to ON position.
4. Turn *Solution Control Knob* counter clockwise slightly to activate flow. The more the lever is turned, the faster the flow of solution. Open completely for maximum flow.
5. Turn *Brush Motor* switch to "ON" position. Do not let the scrubber stay in one position for more than a few seconds after brush rotation has started; damage to floor may result.

6. Begin scrubbing floor by pushing machine forward and walking in straight line. Adjust solution flow accordingly. Be sure to keep hands and feet clear of rotating brush/pad driver.
7. When finished scrubbing, turn both *Brush Motor* and *Vacuum Motor* switches to OFF position.
8. Use your foot to press the bottom of the *Foot Pedal* down until it clicks once, into a locked, raised position, to raise the head.
9. Lift *Squeegee Lift Lever* to raise squeegee off floor and place lever in locked, raised position.
10. Check floor to ensure no puddles have been left by the squeegee or under the machine.
11. Move machine to safe and secure storage area.
12. Check battery charge level and charge batteries if necessary (see **BATTERY MAINTENANCE** and **BATTERY CHARGING** on pgs 14-15).
13. If transporting the ProScrub off site, the *Foot Pedal* can be pushed further down to 2nd locked, "transport" position.
14. If transporting the ProScrub, squeegee can be removed without tools and placed in *Control Panel Cradle* (see below and pg 8 for diagram).

PROSCRUB OPERATION HELPFUL HINTS

- ❖ The ProScrub works best when operating in a straight path; turning the machine at too sharp an angle can result in squeegee spillover
- ❖ While scrubbing, periodically check the recovery tank. If foam buildup is heavy, use a defoamer to prevent damage.
- ❖ If more scrubbing pressure is needed, pull brush lever upwards while operating machine.
- ❖ If squeegee is leaving streaks, lift squeegee to the "UP" position and wipe blades with clean, dry cloth.
- ❖ Before stopping or turning, shut off solution flow to prevent excess solution on the scrub path.
- ❖ If you are stopping for more than five seconds, shut off brushes/pads to prevent floor damage.
- ❖ Frequently check battery meter for charge level. When it drops to the red zone, a recharge is necessary. Do not continue to operate machine after the needle drops into the red zone. Battery damage will occur.

HOW TO REMOVE THE PROSCRUB SQUEEGEE (WITHOUT TOOLS)

1. Using the *Squeegee Lift Lever*, lower the squeegee to the floor (see pg 8 for diagram)
2. Unscrew the two squeegee attachment knobs
3. Disconnect the *Vacuum Hose* from the squeegee
4. Raise the *Squeegee Lift Lever* to the disengaged position, leaving the *Squeegee Lever* disconnected on the floor

STORAGE AND HANDLING SAFETY INFORMATION



Always store equipment away from possible damage by falling objects.

CAUTION

The ProScrub autoscrubber must be secured on a level surface when transporting in a vehicle. Secure the machine in the vehicle so it cannot move or bounce during transporting; damage may occur to the machine and/or the vehicle and surrounding objects.

CAUTION

When charging the scrubber batteries, always disconnect the AC plug before connecting or disconnecting the DC plug to prevent damage or personal injury.

NOTICE

Store in a dry area in the upright position.

NOTICE

After each use, flush both tanks with clean water and drain completely.

NOTICE

Raise, transport and store ProScrub with pad/brush assembly and squeegee off floor to prevent squeegee damage and promote drying.

NOTICE

If storing machine in freezing temperatures, be sure to drain it of all water. Damage to your scrubber due to freezing temperature is not covered under the warranty.

NOTICE

When storing the ProScrub autoscrubber, it is recommended to remove black recovery tank lid to promote air circulation.

MAINTENANCE SCHEDULE

⚠ WARNING

Machine should only be tipped back for service if properly turned OFF, in a safe environment and positioned on a flat surface. Do not tilt machine on its side; damage can occur to the machine, furniture, buildings and/or personal injury. This is a two-person job.

⚠ CAUTION

Do not tilt machine on its side; damage can occur to the machine, furniture, buildings and/or personal injury. Machine should only be tipped back to transport or for service, if properly turned OFF, in a safe environment and positioned on a flat surface. This is a two-person job.

⚠ CAUTION

Before attempting any maintenance or repair on the autoscrubber, make sure that it is on a level surface, that all switches are on the "OFF" position, and disconnect batteries and/or battery charger to prevent any accidental electrical problems, damage or injury.

⚠ CAUTION

To avoid damage to floors, never use overly soiled pads/brushes when scrubbing a floor.

⚠ CAUTION

Store squeegee in the "UP" position to prevent equipment damage.

⚠ CAUTION

Clean machine, tanks and metal surfaces with nonabrasive, non-solvent cleanser to prevent damage to tanks and powder coat finish.

NOTICE

The manufacturer's warranty will be voided if the machine is not maintained in accordance with the recommended maintenance instructions within this Owner's Manual recommended maintenance procedures. Failure to do so may cause damage to the machine, equipment, furniture, buildings, and/or personal injury.

NOTICE

All maintenance must be performed by authorized personnel.

NOTICE

Failure to follow the maintenance schedule could result in non-warrantable failures.

MAINTENANCE SCHEDULE (*CONTINUED*)

DAILY

- Remove and clean pad or brush
- Remove and clean lint from ball float shutoff screen (located in recovery tank)
- Drain and rinse both tanks; remove any clogging debris in vacuum intake hole in recovery tank
- Raise squeegee and wipe with clean, damp cloth to remove any soil
- Recharge batteries if necessary; refer to **BATTERY MAINTENANCE** (see pgs 14-15) as needed

WEEKLY

- Flush tanks and solution lines with vinegar solution: 1 quart (.94L) vinegar and 3 gallons (11.3L) water
- Rinse with clean water
- Clean battery terminals to prevent corrosion
- Check for loose or corroded battery cables
- Check fluid level in batteries (lead acid batteries only)

MONTHLY

- Lubricate axle and caster grease fittings with water-resistant grease
- Lubricate all linkage pivot points with silicone spray, then coat with a water-resistant grease to maintain smooth operation
- Check scrubber for water leaks and loose nuts or bolts

EVERY 250 HOURS

- Check brush motor for carbon brush wear; replace when down to 3/8" or less
- Check vacuum motor for carbon brush wear; replace when down to 3/8" or less

BATTERY MAINTENANCE

CAUTION

Before any battery maintenance is done, make sure batteries and charger are disconnected and unplugged from wall outlet to avoid shock.

NOTICE

Keep battery terminals and surface clean and dry.

- 1.) To dissolve battery corrosion, mix a solution of baking soda and water. Brush solution carefully over battery. Do not allow solution to enter battery cells.
- 2.) After drying, use a wire brush to clean terminal posts and cable connections.
- 3.) After all wires are connected, thoroughly apply a coating of grease to battery terminals to help maintain a good connection and prevent further corrosion.
- 4.) Check for worn or loose cables and replace if necessary.
- 5.) Check fluid level in batteries every 10 charges (lead acid batteries only).

BATTERY CHARGING

WARNING

Battery lead acid may emit explosive gases. Never smoke or use flame or sparks around the batteries.

WARNING

Always unplug power-cord or disconnect batteries before servicing machine. Electric shock may occur.

WARNING

Battery acid can cause burns. Wear protective gloves and eye wear when working with lead acid batteries.

WARNING

Do not store batteries outside or let water, chemicals, or any liquid come into contact with the batteries or the electrical system of the autoscrubber. Damage will occur.

WARNING

Always charge batteries in a well ventilated area, keep hood open, wear eye protection and face shield.

BATTERY CHARGING *continued*

NOTICE

Safety first. Contact an authorized service center as needed.

NOTICE

To get the most life from your battery, recharge when the meter drops into the red zone. Do not continue to run the scrubber after meter has gone into the red zone.

NOTICE

Do not let batteries sit uncharged for long periods of time.

NOTICE

Do not operate this scrubber if it is not in proper operating condition.

NOTICE

GEL BATTERIES: Gel batteries are maintenance free and levels do not need to be checked.

LEAD ACID BATTERIES: Lead acid batteries must have fluid checked every 10 charges. If fluid is low, fill with distilled water to top of plates.

Battery charger specifications:

Output voltage – 24 volts
Output current – 10 to 20 amps
Automatic shutoff circuit

For deep cycle battery charging, life expectancy of a battery is based on the number of charges it receives. To get the most life from your battery, recharge when the meter drops into the red zone.

- 1) Make sure all switches are in the "OFF" position.
- 2) Open recovery tank to access batteries.
- 3) Plug charger into receptacle near battery compartment.
- 4) Plug charger into grounded wall outlet AFTER connecting charger to scrubber. Charger will automatically begin charging and will shut off automatically when batteries are fully charged.
- 5) Do not use an adapter or remove grounded blade on plug.
- 6) After charger has turned off, first unplug it from the wall outlet, then from the scrubber.

SOLUTION TANK PARTS

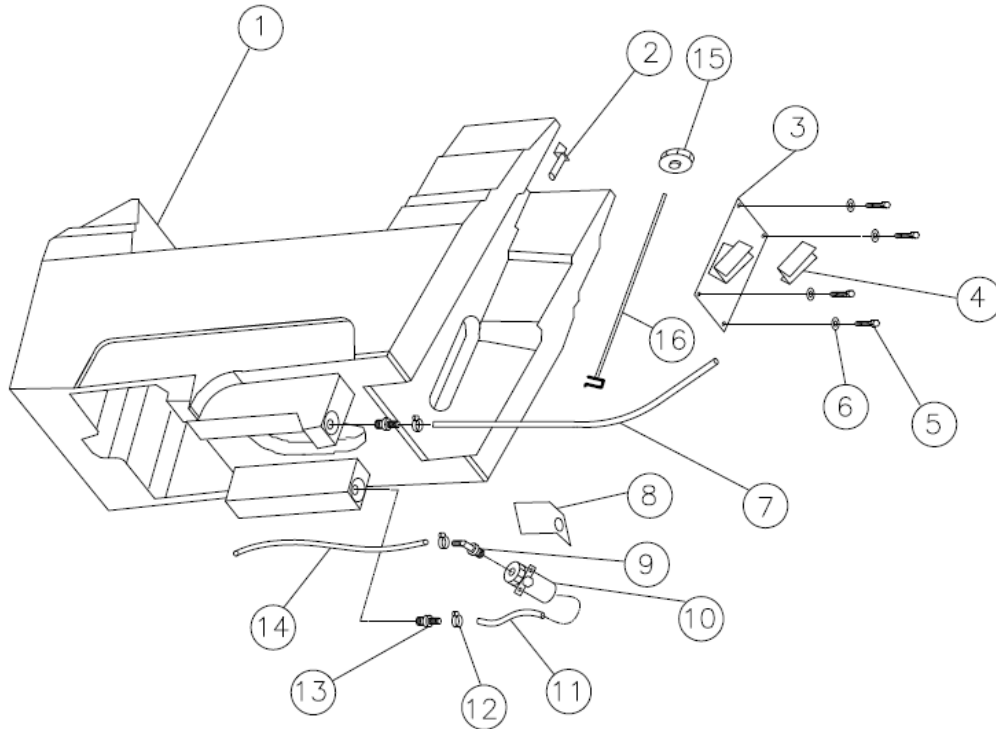

REF #	DESCRIPTION	PART #	QTY
1	SOLUTION TANK	108-AS-1	1
2	DRAIN HOSE BRACKET	288-030-1000	1
3	MOTOR LIFT ADJUST. BRKT.	288-030-700	1
4	FOOT LEVER ADJUST. BRKT.	283-030-105	1
5	3/8 - 16*3/4" BOLT	164-10111	4
6	5/16 USS FLAT WASHER	164-20156	4
7	DRAIN HOSE (SOLUTION TANK)	216-0212	1
8	BRACKET (SOLUTION VALVE)	283-030-115	1
9	VALVE FITTING	166-EL1412	2
10	SOLUTION VALVE	030-20-117	1
11	HOSE	216-0212	1
12	HOSE CLAMP	233-62PO8	4
13	TANK FITTING	166-030	2
14	SOLUTION HOSE	216-0212	1
15	SOLUTION CONTROL KNOB	030-20-103	1
16	SOLUTION CONTROL ROD	288-030-100	1

VACUUM TANK PARTS

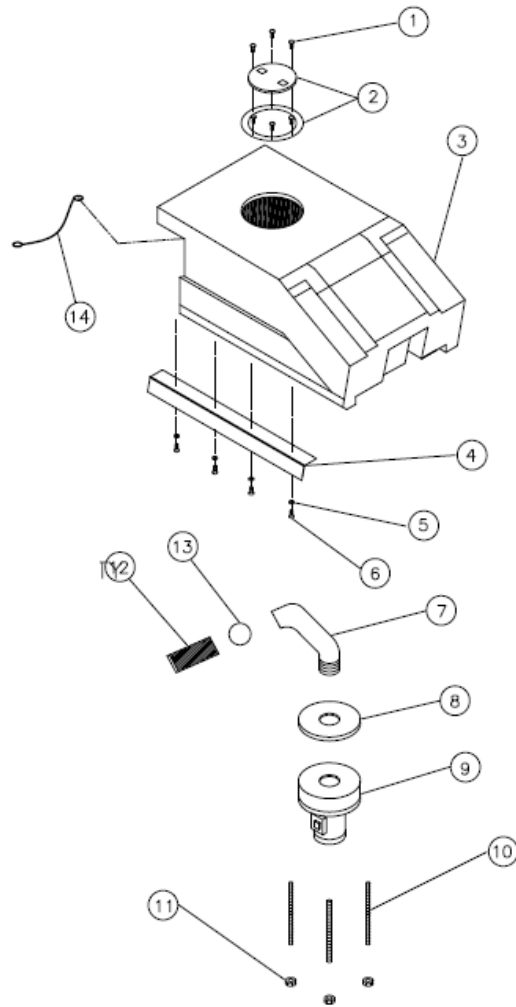

REF #	DESCRIPTION	PART #	QTY
1	SCREW	S2-97	6
2	4" LID	S2-04	1
3	RECOVERY TANK	108-AS-2	1
4	HINGE	030-20H	1
5	WASHER	164-20153	7
6	1/4 - 20*1/2" BOLT	164-10003	7
7	OVERFLOW ASSEMBLY	030-20-119	1
8	VACUUM MOTOR GASKET	S2-20	1
9	VACUUM MOTOR	030-VACM	1
10	1/4 - 20 STUD	164-254	3
11	1/4 - 20 LOK NUT	164-22831	3
12	FLOAT SCREEN	030-20-112	1
13	FLOAT BALL	030-20-111	1
14	SUPPORT CABLE	030-20-116	1
Not shown	RECOVERY TANK DRAIN HOSE	030-20-121	1
Not shown	SQUEEGEE VAC HOSE	S2-47	2
Not shown	HOSE CUFFS	S2-47-CUFF	2

SHROUD ASSEMBLY PARTS

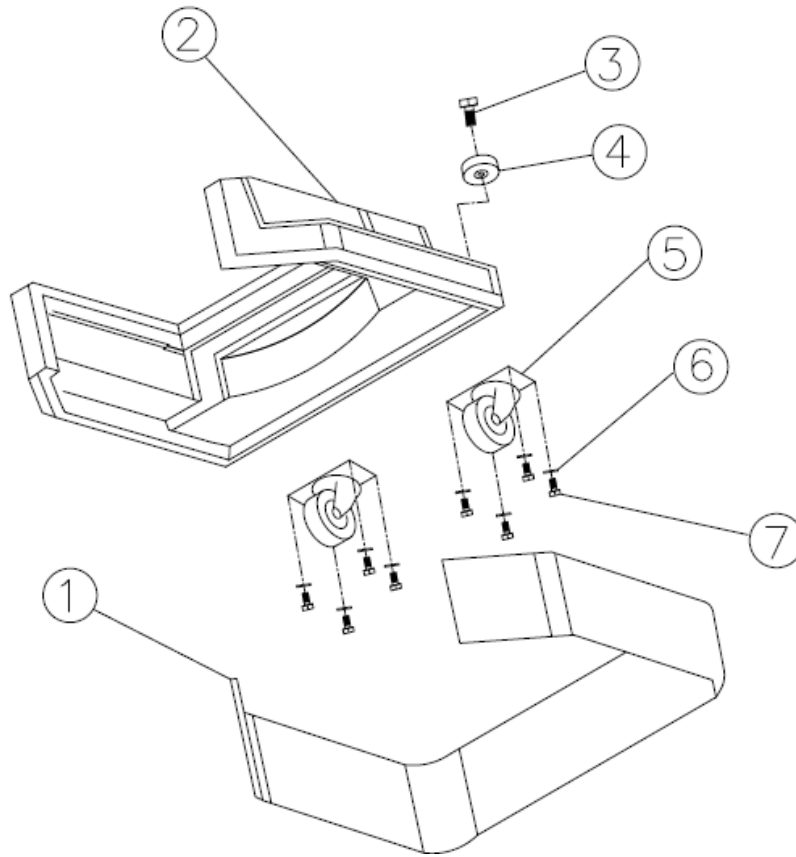

REF #	DESCRIPTION	PART #	QTY
1	SPLASH SKIRT	030-20-118	1
2	BRUSH SHROUD	108-AS-20	1
3	1 3/4" SHOULDER BOLT	196-70212	2
4	POLY WHEEL	156-PB03041-08	2
5	SWIVEL CASTER	156-030	2
6	FLAT WASHER	164-20153	8
7	1/4 - 20*1/2" BOLT	164-10003	8

SQUEEGEE ASSEMBLY PARTS

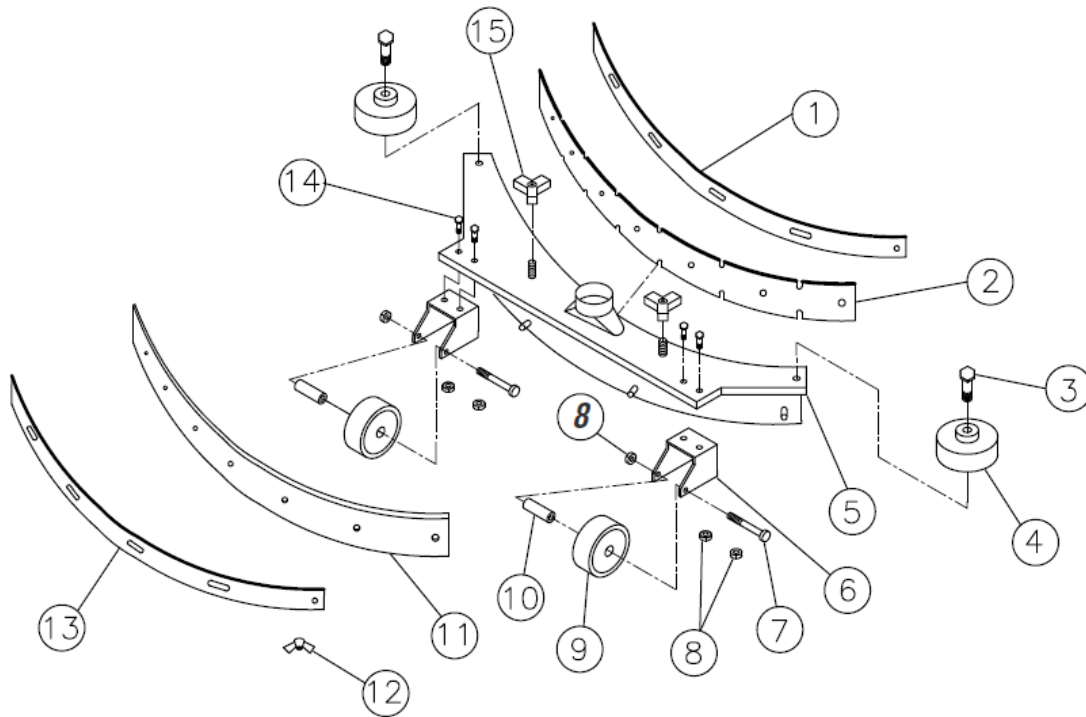

REF #	DESCRIPTION	PART #	QTY
1	FRONT SUPPORT	283-030-235	1
2	SQUEEGEE BLADE (FRONT)	030-20-SRF	1
3	SHOULDER BOLT	196-70212	2
4	POLY WHEEL	156-PB-03041-08	2
5	SQUEEGEE (WELDED ASSBLY)	288-030-200	1
6	WHEEL BRACKET	288-030-221	2
7	WHEEL BOLT	164-1129087	2
8	WHEEL & BRACKET NUT	164-1137015	6
9	WHEEL	156-030-1	2
10	WHEEL BUSHING	030-20-99	2
11	SQUEEGEE BLADE (REAR)	030-20-SRR	1
12	WING NUT	625-6477K58	16
13	REAR SUPPORT	283-030-240	1
14	WHEEL BRACKET BOLT	164-1129061	4
15	SQUEEGEE KNOB	030-20-104	2

DRIVE ASSEMBLY PARTS

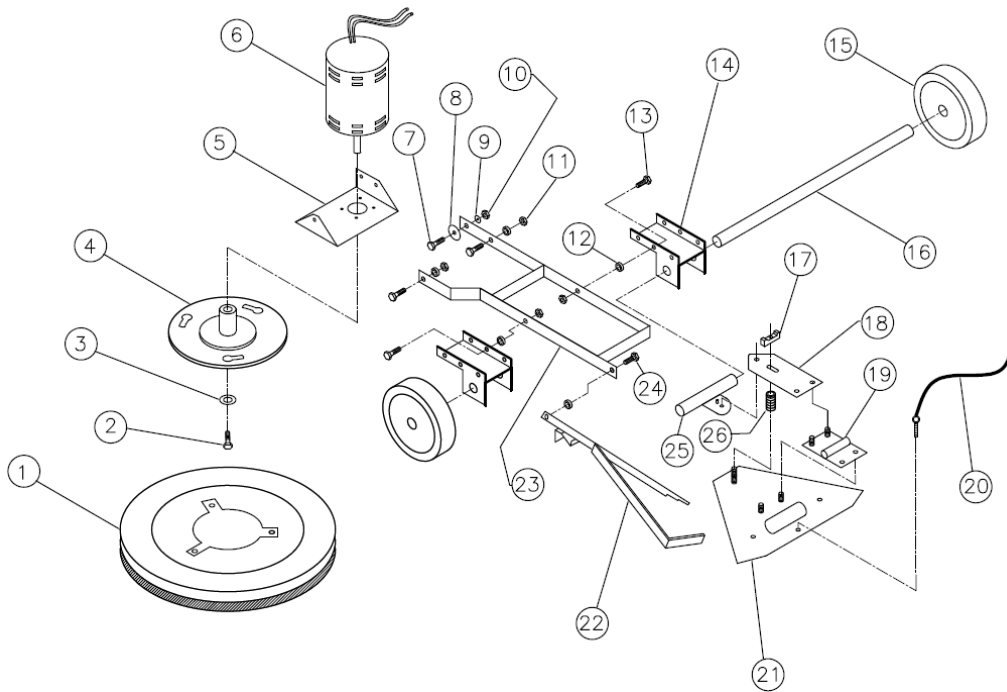

REF #	DESCRIPTION	PART #	QTY
1	20" PAD DRIVER	030-20-262	1
2	5/16 - 18*3/4" BOLT	164-10059	1
3	1/4" FLAT WASHER	164-20155	1
4	MOTOR BRUSH ADAPTER	288-030-800	1
5	MOTOR SWIVEL PLATE	283-030-130	1
6	BRUSH MOTOR	030-BRUSHM	1
7	5/16 - 18*1" BOLT	164-10063	1
8	5/16" FENDER WASHER	164-20207	1
9	5/16" USS FLAT WASHER	164-20156	1
10	5/16 - 18 STOVER LOK NUT	164-22833	1
11	1/2 - 13 STOVER LOK NUT	164-22836	4
12	CHASSIS BUSHING	030-20-100	5
13	1/2 - 13*1" BOLT	164-12011	4
14	CHASSIS MOUNT BRACKET	288-030-500	2
15	8" WHEEL	156-XA-08251-12	2
16	AXLE	283-030-280	1
17	KNOB	164-14FN	1
18	SQUEEGEE PIVOT BRACKET	283-030-250	1
19	SQUEEGEE PIVOT HINGE	030-20-106	1
20	SQUEEGEE LIFT CABLE	030-20-115	1
21	SQUEEGEE MOUNT PLATE	283-030-245	1
22	MOTOR LIFT FOOT BRACKET	288-030-600	1
23	PIVOT CHASSIS	288-030-400	1
24	3/8 - 16*3/4" BOLT	164-10111	1
25	AXLE/SQUEEGEE PIVOT BRACKET	288-030-900	1
26	SQUEEGEE ADJ. SPRING	030-20-105	1

CONTROL PANEL PARTS

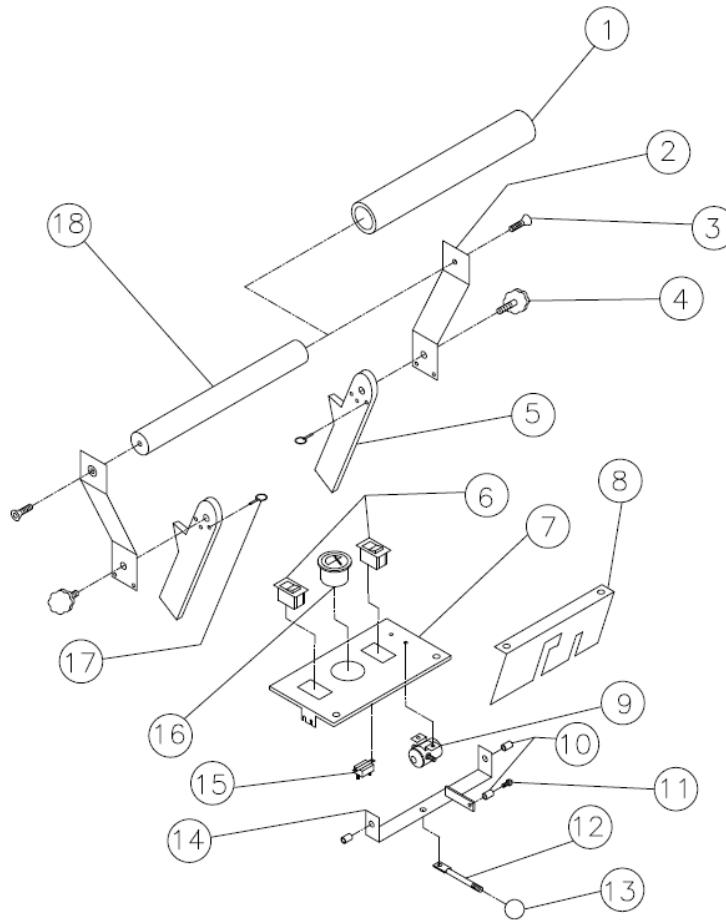

REF #	DESCRIPTION	PART #	QTY
1	HANDLE GRIP (FOAM)	030-GRIP	1
2	HANDLE ADJUSTMENT BRACKET	283-030-125	2
3	HANDLE BOLT	164-132DA23020P	2
4	HANDLE ADJUSTMENT KNOB	030-20-114	2
5	HANDLE BASE BRACKET	283-030-120	2
6	ROCKER SWITCH	030-20-108	2
7	CONTROL PANEL PLATE	283-030-275	1
8	COVER PLATE	283-030-270	1
9	SOLENOID	153-030	1
10	BUSHING	030-20-101	3
11	BOLT	164-10007	1
12	SQUEEGEE LIFT ARM	288-030-300	1
13	SQUEEGEE LIFT KNOB	030-20-102	1
14	SQUEEGEE LIFT BRACKET	288-03-1100	1
15	CIRCUIT BREAKER	030-20-109	1
16	BATTERY CONDITION METER	153-314	1
17	HANDLE ADJUSTMENT PIN	030-20-107	2
18	HANDLE BAR (NO FOAM GRIP)	2880030-1300	1

WIRING DIAGRAM

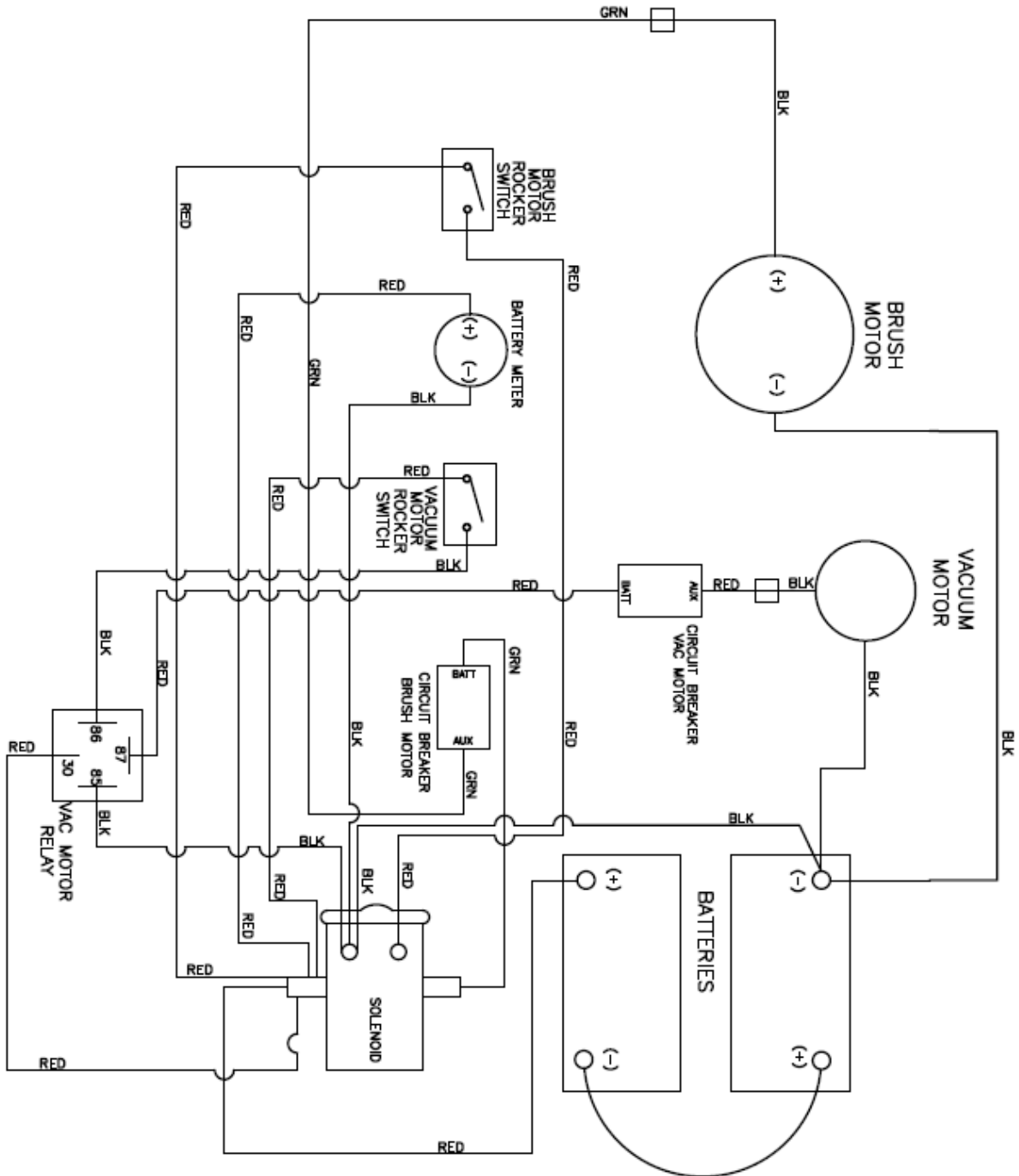

TROUBLESHOOTING

PROBLEM	SYMPTOM	SOLUTION
No power, nothing runs	Batteries need charging Batteries faulty Loose battery cable Batteries not connected properly	Charge the batteries Replace batteries Tighten cable connection Connect properly
Brush motor does not run	Faulty brush switch Machine circuit breaker has tripped Faulty wiring Faulty brush motor Carbon brushes worn Faulty solenoid	Contact service center Allow motor to cool down, breaker will automatically reset Contact service center Contact service center Replace if worn to 3/8 or less Contact service center
Vacuum motor does not run	Faulty vacuum switch Faulty wiring Faulty vacuum motor Carbon brushes worn	Contact service center Contact service center Contact service center Replace if worn to 3/8 or less
Short run time	Batteries not fully charged Bad cell in one or more batteries Batteries need maintenance Faulty charger	Charge batteries Replace battery See "Battery Maintenance" Replace charger
Little or no solution flow with knob in open position	Solution flow lever is not activated Solution line is clogged Solution valve is clogged Rod does not rotate when knob is turned on	Push flow lever forward Remove hose and blow compressed air through it. Then flush with clean water Remove valve and clean. Do not scratch or damage inside Solution flow adjustment knob needs adjusting with set screws
Poor squeegee pickup	Recovery tank is full Ball float shutoff screen is clogged Squeegee is clogged with debris Squeegee blades are worn Squeegee thumbscrews are loose Vacuum hose connections are loose Vacuum hose is worn or has a hole Vacuum is clogged with debris Tank gasket is defective Recovery tank water inlet is plugged Recovery tank lid is loose Vacuum motor is loose Battery charge is low	Empty tank Remove screen and clean Clean squeegee Replace blades Tighten screws Push hose firmly onto connections Replace Remove debris Replace gasket Empty recovery tank and tilt sideways And flush in water to remove clogged debris Tighten lid Tighten down vacuum motor, do not over-tighten! Do not run scrubber if meter is in the red zone

RETURN GOODS POLICY

The ProScrub autoscrubber is an innovative and unique machine. Since it was first introduced it has undergone a process of continuous improvement. This has been accomplished based on comments and suggestions by customers and by the return of any defective or failed parts. Examining causes of failures firsthand allows us to solve current problems and avoid them in the future. While this may at first seem to be an inconvenience, ultimately you benefit from safer and more reliable products. Please give us the opportunity to serve you better by following these RGA (Return Goods Authorization) rules.

Aztec maintains the serial number, date of shipment or sale, and customer name on each piece of equipment sold. If you were the purchaser, please reference that information on your request for replacement or repair. If you purchased the equipment through a dealer, please contact them.

Order the replacement part from your Distributor, or call Aztec: 800-331-1423. We will ship warranted parts at our expense.

Get an RGA number when you are ordering the replacement part. Return the failed part to us within 30 days, freight prepaid, exactly as it was at the time of failure. Our inspection and evaluation will attempt to determine the probable cause of failure.

If our inspection reveals that the failed part was defective, we will credit your account for the entire amount of the part including your cost of return freight.

We intend to be reasonable on any matter that is related to our warranty service or other wear-related problems which our customers feel need attention. Please help us to help you. Before assuming that a part is defective, check the repair manual to see if the problem might be something that you or one of your employees might be capable of correcting. If it is not, follow the above policy and depend on us to respond quickly and responsibly.

RETAILER/DISTRIBUTOR CONTACT INFO

PURCHASE DATE:

DISTRIBUTOR NAME:

DISTRIBUTOR PHONE NUMBER(S):

NOTES:

AZTEC PROSCRUB WARRANTY

This quality product is warranted to be free from defects in workmanship and materials. The warranty is limited as follows:

COMPONENT	TERM OF WARRANTY
Rotational molded parts	3 years
Vacuum Motor	1 year
Brush Motor	1 year
Batteries	1 year by Manufacturer *
Charger	1 year by Manufacturer †

The warranty does not apply to certain consumable or wear parts such as:

Squeegee Blades
Motor Carbon Brushes

The warranty does not apply to damage or failure caused by abuse, misuse, neglect, disassembly, alteration or repair, lack of proper maintenance, theft, or damage by freight carriers. The warranty applies to parts, labor, and ground freight only. It does not cover incidental or consequential damages.

In order to obtain parts warranty, the following procedure must be followed:

1. Customer must call the Distributor for an RGA (Return Goods Authorization) number.
2. Return defective part via prepaid ground freight to your purchase source with RGA number clearly marked on packaging. Enclose a copy of the original purchase invoice.
3. Pack machine or parts carefully for return. We are not responsible for inbound freight damage.
4. Only authorized dealers may make warranty repairs.

The need for proper care and maintenance for this product cannot be overstated. Poor maintenance, neglect or abuse can void this warranty. Never leave your machine in a truck or outside storage area where there is a potential for freezing. Read and follow the Maintenance Schedule in your Owner's manual.

Vacuum motors carry a one-year warranty, however motors showing any of the following signs of abuse will be excluded from coverage:

- a. Signs of moisture in or on the fan/mount chamber area. (This means that water or foam has been sucked through the motor, voiding the warranty.)
- b. Dirty motors, where failure has been caused by inadequate filtering resulting from a failure to maintain motor and keep filter clean.

You have purchased a quality product. Each of its components has been tested and approved for use in this application. It is unlikely that you will ever have a warranty claim if you properly maintain your machine.

* Battery warranty is one (1) year from battery manufacturer, call Aztec for information: 800-331-1423

† Charger warranty is one (1) year from charger manufacturer, Lester Electrical: 402-477-8988

This warranty is non-transferable.

AZTEC PRODUCTS, INC. • www.aztecproducts.com

201 Commerce Drive • Montgomeryville, PA 18936 • 800-331-1423 • Fax 215-393-4800